

MONTAGGIO CONDENSATORE

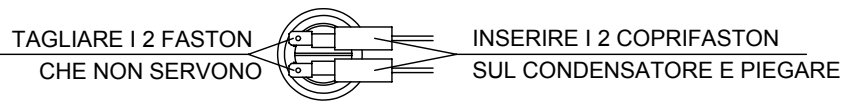

N.B: ESEGUIRE N° 3 FORI Ø16 SULLA SCATOLA MORSETTIERA PER IL FISSAGGIO DEI PRESSACAVI

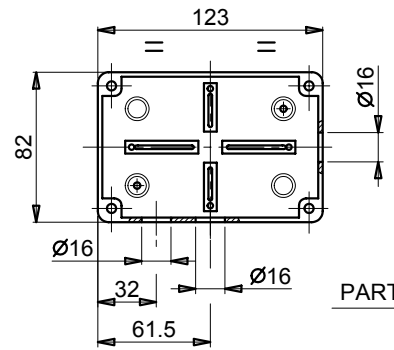

PART. FORATURA SCT MORS.

NICOTRA Gebhardt Nicotra Gebhardt S.p.A. Stabilimento di Zingonia - BG	CREATED BY P.GARAVELLI	CONTROLLED BY		GENERAL TOLERANCE UNI ISO 22768/v
	DATE 04/10/2005	SCALE 1:3	MATERIAL VEDI COMPONENTI	
DESCRIPTION DD 9/9 M9F5 1F 4P 1V +SCT	CODE / REVISION 6M066N / 03			
Note	MODEL	PAGE 1	PAGES 1	REPLACE 6M0663/02

Ind.	Date	Description
00	05/05/2005	RIEMESSO DISEGNO E AGGIUNTO NOTA DI PUNZONATURA PER FCT SX R.MAGONI
01	29/11/2005	SOSTITUITO COD 144134 CON COD 144135 RCC N° 585 UTP DEL 14/1/2005 R.MAGONI
02	05/02/2008	SOSTITUITO CODICI COMPONENTI CON GR COCLEA CPL RCC N° 434/06 UTP M.RAGUSA
03	24/11/2009	SOSTITUITO CCL. SALDATA CON CCL. AUT. SOSTITUITO DEFL. AGGIUNTO NUTSERT E ELIMINATO ETICHETTA SENSO DI ROTAZIONE F.PANSERA
04		
05		
06		
07		
08		

Pos.	Componente	Descrizione	Categoria art.	Revi- sione	Lung. [m]	Larg. [m]	Numero unità	Quantità netta	UM	Info. extra
Disegno : 6M066N		DD 9/9 M9F5 1F 4P 1V +SCT						Unità DB:	1 pcs	
Vers. dis. :		REVISIONE 03								
10	7A00055ZZ0000000	CCL 9/9 AT AUT	art. tec.	00				1,0000	pcs	
15	920603	NUTSERT QUADRO M5 ZINC	art.	00				3,0000	pcs	
20	8A60055ZZ0000000	DEFL 9/9 AT C/PIEGA	art. tec.	02				1,0000	pcs	
30	914900	VITE AUTOF C/ROND §4,2X22	art.					2,0000	pcs	
40	731308	VLA DD 9/9 §12,7	art. tec.	00				1,0000	pcs	
50	7M29N7	GR MRE DD 9 M9F5 11/09	art. tec.	00				1,0000	pcs	
60	914919	VITE TE FL.ZIGR.M5X16 UNI22768	art. tec.	00				3,0000	pcs	
70	144034	SCATOLA MORSETTIERA EC 410C4R	art. tec.	01				1,0000	pcs	
80	140928	PRESS/CONTRODADO EC 51009	art.					3,0000	pcs	
90	914109	VITE AUTOF.3,5X 9,5	art.					2,0000	pcs	
100	144036	MORS.VITE 4 P.TIPO PA27XA1F	art.					1,0000	pcs	
110	143092	COND+CAP 16MF V500 (cl.P2)	art. tec.	01				1,0000	pcs	
120	144135	COPRIFASTON FRONT.NYLON 6,3	art. tec.	00				2,0000	pcs	
130	985094	ETICHETTA PRESENZA TENSIONE	art. tec.	01				1,0000	pcs	
150	985014	ETICHETTA AUTOADESIVA VRE	art. tec.	01				4,0000	pcs	
160	985537	ETICHETTA AUTOADES.CONTROLLO	art.					1,0000	pcs	
170	985713	DICHIARAZIONE DEL FABBRICANTE	art. tec.	08				1,0000	pcs	
180	171552	SCAT IMB 9/9 CPL 500X420X390	art. tec.	02				1,0000	pcs	
190	174121	GRAF.XCUC.ROL 5/8	art. tec.	00				10,0000	pcs	
200	175002	PALLET 100 X 120	art. tec.	01				0,0420	pcs	